

# INFINITY2-1R

Research-grade 1.4 megapixel CCD USB 2.0 camera

Scientific digital imaging for documentation and image analysis in Life Science, Clinical and Material Science Applications



## INFINITY2-1R

The newly engineered INFINITY2-1R scientific camera offers a significant performance increase for quantitative and low-light applications over its predecessor. Reduced operating temperatures combined with a much higher dynamic range and 14-bit output have resulted in a versatile entry-level research camera. The INFINITY2-1R easily manages seconds of exposure time with a dark current rating of less than 1 e-/s.

### Superior Sensitivity

The INFINITY2-1R has a dynamic range of 64 dB allowing users to image unevenly lit samples without worry. The resulting images show detail in bright and dark areas not normally seen in lower dynamic range cameras. Advanced thermal management allows for long exposure times of several minutes without the need for a higher priced cooled camera.

### Full Image Analysis Software Included

INFINITY CAPTURE, an intuitive image capture program, and INFINITY ANALYZE, a full image analysis package offering; camera control, measurement, annotation, tiling and post capture enhancement, are both included. Camera and software combined to create a complete microscopy imaging solution for your application.

### USB 2.0 Plug-and-Play Interface

Sharing and installation of one or more cameras on a single computer is quick and simple through a high-speed USB 2.0 interface.

### Third-Party Software Integration

INFINITY cameras are integrated into a variety of third-party software packages through direct drivers or with TWAIN/DirectX support.

### Mac Camera Software

A Mac camera driver and ImageJ plug-in are available for the INFINITY2-1R. Please refer to the Lumenera web page [www.lumenera.com](http://www.lumenera.com) for up-to-date details.

### Superior Technical Assistance Center (TAC)

As a Lumenera customer you gain access to the TAC group and knowledge base, which provide full support for cameras, software and microscopy applications.

## Features

- Improved noise performance over the first generation camera
- Incredibly low dark current noise in an uncooled camera
- High dynamic range of 64 dB
- Low noise progressive scan 1/2" 1.4 megapixel Sony ICX205 CCD sensor
- Full color sub-windowing allows for rapid focus and scanning of samples; up to 30 fps at full resolution
- 8 or 14-bit pixel data modes
- Software compatible with Windows XP, Vista and 7, 32 and 64-bit
- Includes TWAIN and DirectX / Direct Show support

## Recommended Applications

- Brightfield
- Darkfield
- Live Cell Imaging
- Histology
- Pathology
- Cytology
- Defect Analysis
- Semiconductor Inspection
- Metrology
- Gel Documentation
- Low Light Fluorescence
- Quantitative Analysis

## Warranty

- Two (2) years parts and labor

## Microscope Coupler

- Requires 0.5 x C-mount coupler



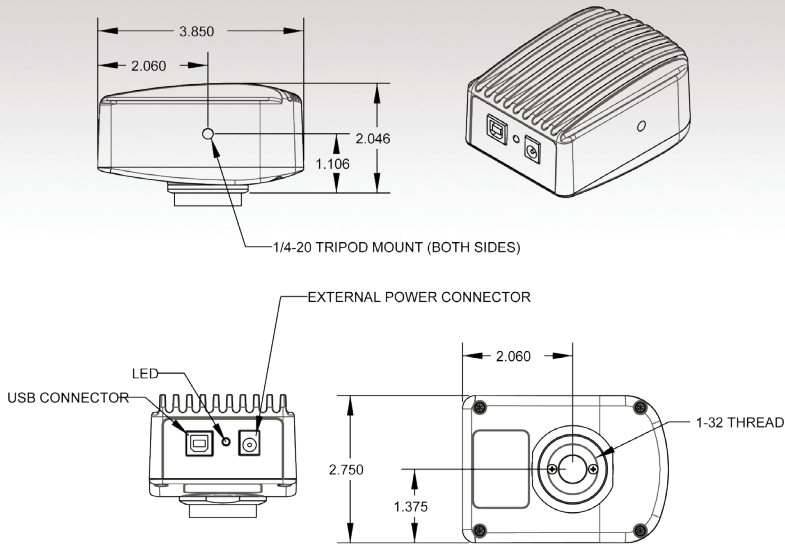

Monochrome Quantum Efficiency

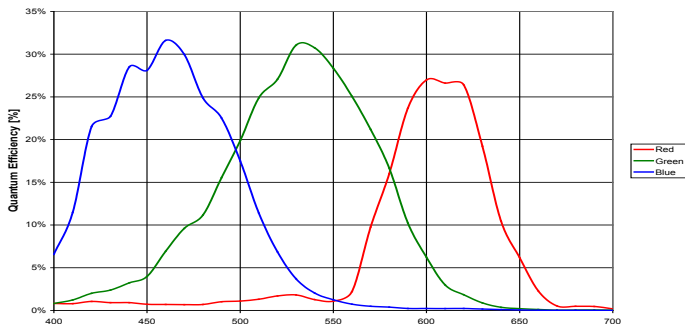

Color Quantum Efficiency

Ordering Information	
INFINITY2-1RC	1.4 MP CCD Color Camera
INFINITY2-1RM	1.4 MP CCD Monochrome Camera
INFINITY ANALYZE MODULE	INFINITY ANALYZE Advanced Features Module (Multi-Focus Composition and Spherical Aberration Correction Features)
LuSDKSW	Software Developer's Kit (Web Download)
LuSDKSW-DVD	Software Developer's Kit (DVD)
La20515	5 V DC, 2.5 A, 12.5 W Power Supply

Sensor Specifications	
Image Sensor	Sony HAD ICX205, CCD, color/mono, progressive scan
Optical Format	1/2"
Active Area	7.6 x 6.2 mm
Pixel Size	4.65 x 4.65 $\mu$ m
Resolution	1392 x 1040 pixels
Region of Interest Control	Any multiple of 8 x 8 pixels, 120 x 120 pixels minimum
Camera Specifications	
Frame Rate	Up to 30 fps at full resolution (1392 x 1040) 52 fps at 640 x 480 (ROI)
Bit Depth	8 or 14-bit
Binning Modes	2 x 2, 4 x 4 binning modes
Exposure Control	Manual and automatic control
Exposure Range	48 $\mu$ s to 500 ms (video), 5.4 $\mu$ s to 8 min (snapshot)
Gain Control	Manual and automatic control
Gain Range	0.5 to 15 x
White Balance	Manual and automatic control
Camera Characteristics (@ 4.7 fps)	
Sensitivity	2.5 DN/(nJ/cm <sup>2</sup> ) [at 8-bit, 1 x gains]
Dynamic Range	64.6 dB
Full Well Capacity	14,500 e-
Quantum Efficiency	32 % (peak color) 44 % (peak mono)
Read Noise	8.5 e-
Dark Current Noise	< 1 e-/s at 22 °C
Mechanical Specifications	
Data Interface	USB 2.0
Lens Mount	Adjustable C-mount standard
Dimensions (enclosed)	57.15 x 97.79 x 39.624 mm 2.25 x 3.85 x 1.56 inch
Mass	340 g
Operating Temperature	0 to 50 °C
Storage Temperature	-30 to 70 °C
Operating Humidity	5 to 95 %, non-condensing
Shock / Vibration	50 G shock, 5 G (2 to 200Hz) vibration
Camera Software	
Operating Systems	Windows XP, Windows Vista, Windows 7, Mac OSX, 32 and 64-bit
Power and Emissions	
Power Consumption	~2.5 W
Power Requirement	USB bus power (external 5 V DC, 500 mA)
Emissions Compliances	FCC Class B, CE Certified
Hazardous Materials	RoHS, WEEE Compliant
Warranty	One (1) year
System Requirements	
Recommended PC Specs:	<ul style="list-style-type: none"> <li>Pentium 4, 1.3 GHz or higher</li> <li>512 MB RAM</li> <li>500 MB hard drive free space or more</li> <li>USB 2.0 Port</li> <li>Windows 7</li> </ul>
Minimum PC Specs:	<ul style="list-style-type: none"> <li>600 MHz Processor</li> <li>256 MB of RAM</li> <li>200 MB hard drive free space</li> <li>USB 2.0 Port</li> <li>Windows XP</li> </ul>
Included In The Box	
INFINITY2-1R	1.4 MP Digital Camera for USB 2.0
LuINFSW-DVD	DVD with INFINITY user application software, TWAIN driver and documentation
Lu802	2 m USB 2.0 Cable

